

model no:

DS101D, DS102D, DS201D, DS202D, DS305D, DS306D,
DS307D, DS310D, DS311D, DS312D, DS405D, DS406D,
DS410D, DS411D, DS101T, DS102T, DS106T, DS201T,
DS202T, DS206T, DS300T, DS301T, DS302T, DS305T,
DS306T, DS307T, DS310T, DS311T, DS312T



WABASH VALLEY

DESIGNER SERIES

4', 6' & 8' SINGLES, 6' & 8' PICNIC TABLES & DOUBLE BENCHES
PORTABLE, INGROUND & SURFACE MOUNT

© Wabash Valley Manufacturing, Inc.

customer service:

ASSEMBLERS: If you find any parts missing or damaged, or if you're having difficulty assembling your furniture/equipment, call us at:

* Before calling, have your product model number available.

1-800-253-8619 (Inside U.S.A.)
260-352-2102 (Outside U.S.A.)
Monday thru Friday,
8:00 AM - 4:30 PM Eastern Time
(EXCEPT HOLIDAYS)

Any correspondence concerning our product should be sent directly to our Customer Service Manager at:

Wabash Valley Manufacturing, Inc.
505 E. Main Street
P.O.Box 5
Silver Lake, IN 46982 U.S.A.
FAX: 260-352-2160

maintenance:

Regular inspection and maintenance of all parts, and fasteners is necessary. Tighten all bolts and nuts. Inspect Tops, Seats, Legs, Braces and Fasteners periodically for wear or vandalism. Replace broken or worn parts immediately or take equipment out of service until repairs are made. Use genuine Wabash Valley replacement parts.

To restore plastisol coating to its luster after prolonged use, wash/rinse/dry and use Armor-All ® or similar quality vinyl protectant.

KEEP THIS ASSEMBLY/SPECIFICATION SHEET FOR FUTURE REFERENCE.

specifications:

NOTE: We reserve the right to change specifications without notice.

Heat fused poly-vinyl coating, finished on inner-metal structure, to an approximate 3/16" thickness. Framework assemblies are finished with powder coating; electrostatically applied and oven cured according to powder manufacturer's specifications. Fasteners are stainless steel to resist corrosion.

TABLE FRAME:

Main support is constructed from a 4" x 4" x 11 gage galvanized structural steel square tubing. The top's inground post mounting brackets are 1/4" x 1 1/2" x 1 1/2" angle iron. The seat's inground post mounting brackets are 1/4" x 1 1/2" flat bar steel. Both post's top plates are 4 1/2" x 4 1/2" x 10 gage sheet steel. Surface mount base plates are 1/4" plate steel. Cover plates are cast aluminum.

TOPS & SEATS:

Designer tops and seats use fabricated 3/4" #9 expanded steel mesh. Framing consist of die formed 14 gage mitered angles 3/4" x 4". Traditional tops and seats are 10 gage sheet steel. The top and seats support braces are 1/4" x 1 1/2" flat bar steel. The top and seats support braces are 1/8" x 1" strip steel.

GENERAL:

6' table and benches ground space requirements are 68 5/8" x 72 3/8".

8' table and benches ground space requirements are 68 5/8" x 96 3/8".

4' single bench ground space requirements are 15 3/8" x 48 3/8".

6' single bench ground space requirements are 15 3/8" x 72 3/8".

6' double bench ground space requirements are 30 3/8" x 72 3/8".

8' single bench ground space requirements are 15 3/8" x 96 3/8".

8' double bench ground space requirements are 30 3/8" x 96 3/8".

On all tables and benches It is 30" to the top of the table and 19" to the top of the seat except the portable seats, they are 17 1/4" to the top of the seat.

parts identification:

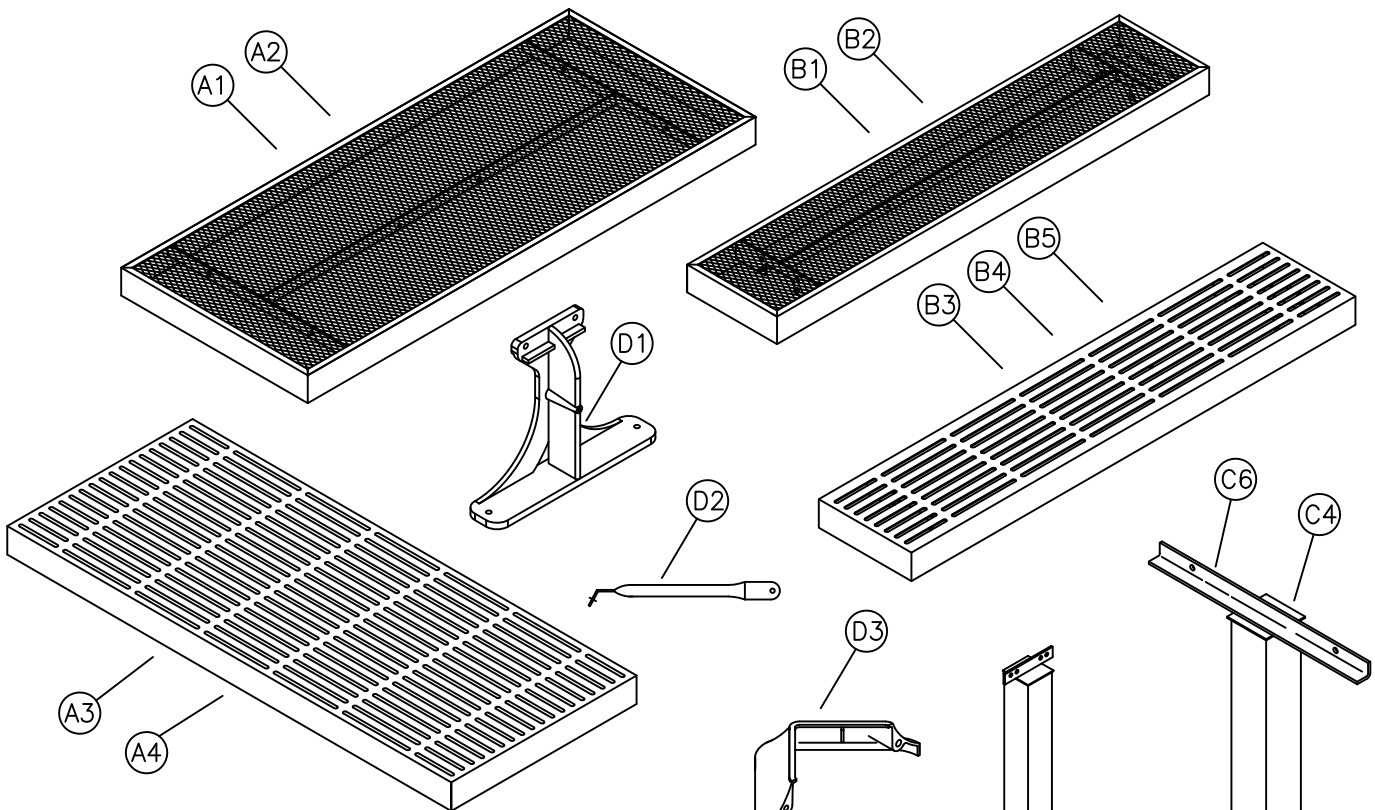

ITEM	PART#	DESCRIPTION	QTY
A1	7515	6' DESIGNER TOP OR DOUBLE BENCH	1
A2	7514	8' DESIGNER TOP OR DOUBLE BENCH	1
A3	7860	6' TRADITIONAL TOP	1
A4	7861	8' TRADITIONAL TOP	1
B1	7553	6' DESIGNER SEAT	1 OR 2
B2	7551	8' DESIGNER SEAT	1 OR 2
B3	7556	4' TRADITIONAL SEAT	1
B4	7554	6' TRADITIONAL SEAT	1 OR 2
B5	7552	8' TRADITIONAL SEAT	1 OR 2
C1	7323	SINGLE SEAT SURFACE MOUNT POST	4
C2	7410	TOP T-POST SURFACE MOUNT	2 OR 3
C3	7322	SINGLE SEAT INGROUND POST	4
C4	7305	TOP T-POST INGROUND	2 OR 3
C5	7312	DOUBLE SEAT T-POST SURFACE MOUNT	2
C6	7311	DOUBLE SEAT T-POST INGROUND POST	2
D1	7362	PORTABLE LEG	2
D2	7281	PORTABLE LEG BRACE	2
D3	7151	MOUNTING PLATE COVER (OPTIONAL)	2 OR 6

hardware identification:

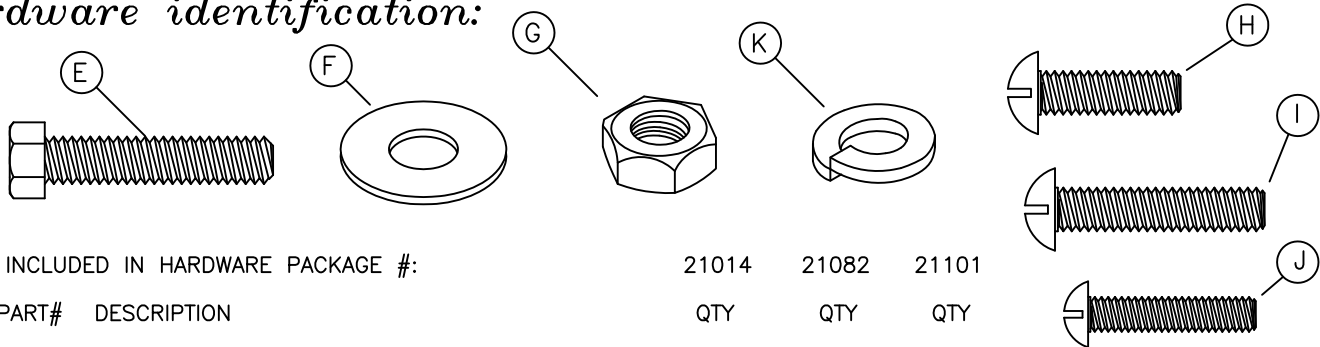

ITEMS INCLUDED IN HARDWARE PACKAGE #:			21014	21082	21101
ITEM	PART#	DESCRIPTION	QTY	QTY	QTY
E	17011	5/16-18 x 1 1/2" HEX HEAD BOLT - SS	4	2	0
F	17028	3/8" FLAT WASHER - SS	8	14	0
G	17032	5/16-18 HEX FINISH NUT - SS	4	6	0
H	17088	5/16-18 x 1" TRUSS HEAD MACHINE SCREW - SS	0	2	0
I	17012	5/16-18 x 2" HEX HEAD BOLT - SS	0	4	0
J	17052	1/4-20 x 1" MACHINE SCREW - SS	0	0	2
K	17050	5/16" SPLIT LOCK WASHER - SS	4	6	0

ASSEMBLY TOOLS REQUIRED

- 1 - FLAT SCREW DRIVER
- 2 - 1/2" WRENCHES
- 1 - 3' OR 6' LEVEL

assembly procedures:

IMPORTANT: Assemblers should be reasonably skilled in the assembly of commercial grade/heavy duty fabricated steel equipment.

To ensure proper assembly, it is suggested that you take adequate time to locate and identify each part. To prevent scratching of the finished pieces, we recommend this unit to be assembled on a clean, flat, solid, surface with a drop cloth, allowing plenty of working room. Also please read the instructions and study the sketches very carefully. A little extra time spent before assembly will be well worth it in performing a complete, proper assembly. Please note that all parts have been pre-cut and pre-drilled.

During the assembly process leave all bolts and nuts "finger tight", until the entire unit is completely assembled. This allows room for movement to level or adjust all seats, tops, benches, framework and braces if necessary. After final adjustment and leveling, permanently tighten all nuts, bolts and fasteners.

7L

STEP 1 - FOR INGROUND AND SURFACE MOUNT UNITS

Invert the top (A-) or seat (B-) upside down on a flat surface. Attach both of the (C-) to the outside of the top's mounting brackets, see FIG. 1 for tables or FIG. 2 for benches. Use two per each leg, (E) and (G), using two (F) and one (K) per (E). Draw the fasteners to a snug fit with wrenches. NOTE: Bolt center leg (C4 or C6) to (A5) top. Follow steps as stated above. See FIG. 1a.

For Inground unit:

STEP 2

Prepare foundation holes as shown on page 4 or 5. The distance of holes, center to center, are shown in a detailed diagram on page 4.

STEP 3

Re-invert the units to their upright position and place them in the footing holes. Block the table and/or bench(es) as shown in FIG. 3.

Before pouring concrete, make sure the table and seats are level horizontally as well as vertically and holds 30" to the top of the table, and 19" to the top of the seats. Tighten all fasteners with wrenches. Pour concrete to form the footings and let cure for 48 hours.

For Surface Mount unit:

STEP 2

Prepare and place the foundations securement hardware in its new location. The diagram on page 4 gives a detailed diagram of where the hole locations should be placed.

When the foundation securement hardware has been installed, place the unit in its chosen location and secure to the foundation. Tighten all fasteners with wrenches.

If mounting plate covers (D3) are used on the surface mount and inground legs, place the covers around the legs and secure with 2 (J) screws, see FIG. 6. Bring to a snug fit. Do not over tighten.

STEP 1 - FOR PORTABLE UNITS

Invert seat top (B-) upside down on a flat surface. Attach both Gullwing legs (D1) to the inside of the seat's mounting brackets, see FIG. 4. Use two, per each leg, (I) and (G) using two (F) and one (K) per (I). Attach brace (D2) to leg using one (H) and (F), see FIG. 4. Attach other end of brace to seat support using one (E) and (G) using two (F) and one (K) per (E), see FIG. 5. Tighten all fasteners with wrenches and set bench upright.

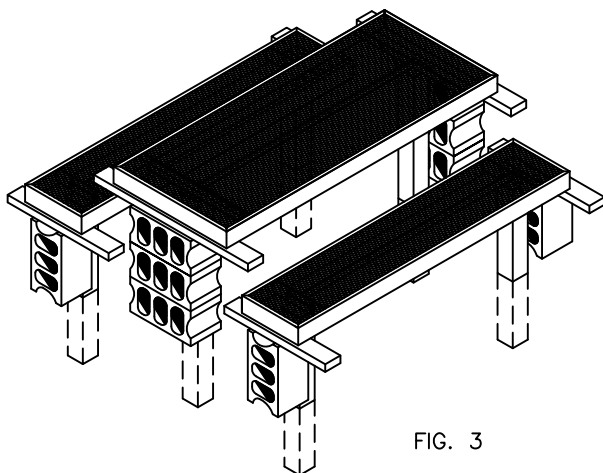

FIG. 3

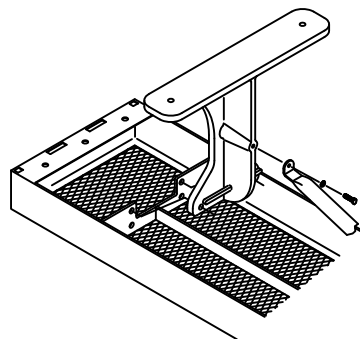

FIG. 4

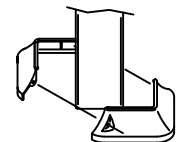

FIG. 6

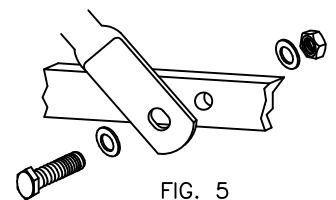

FIG. 5

installation:

WARNING: The proper installation for Wabash Valley products may depend upon many factors unique to the site, location, or use of a particular product. Consult with your contractor or other professional to determine your specific installation requirements.

product dimensions:

INGROUND UNITS W/SEATS

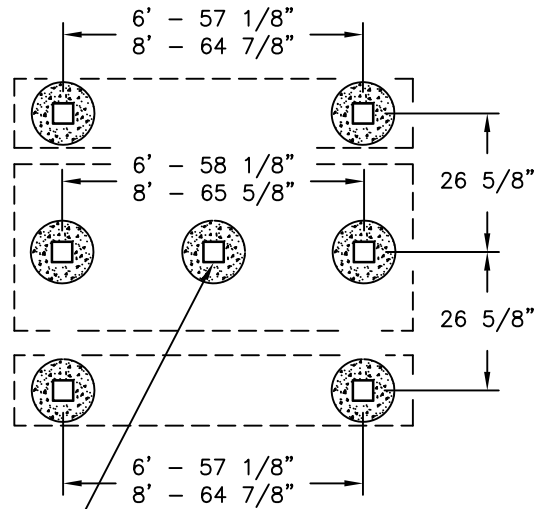
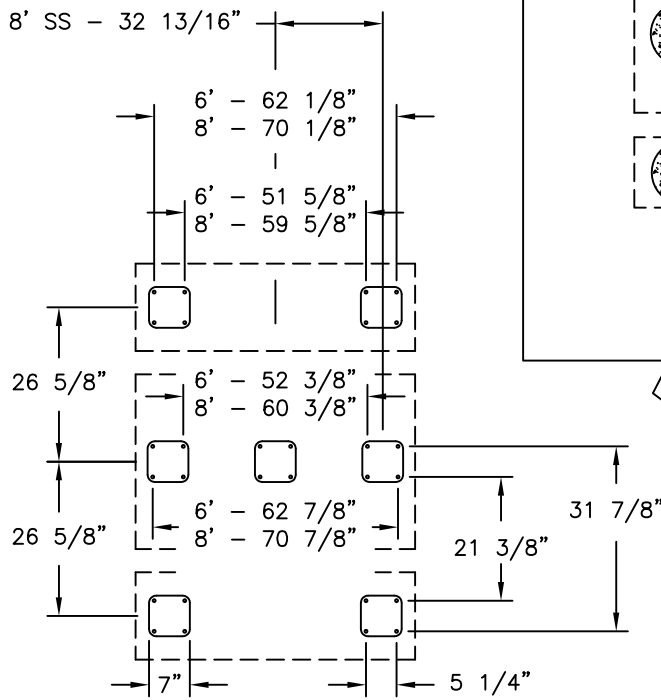
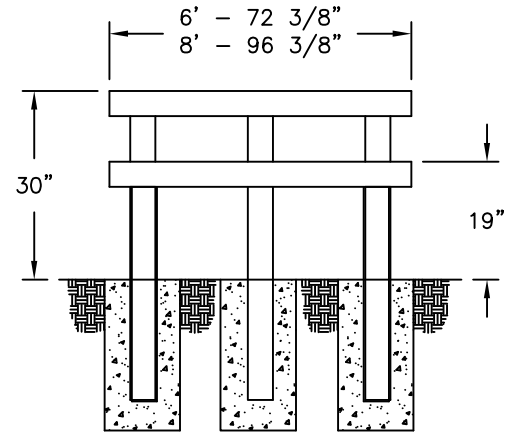
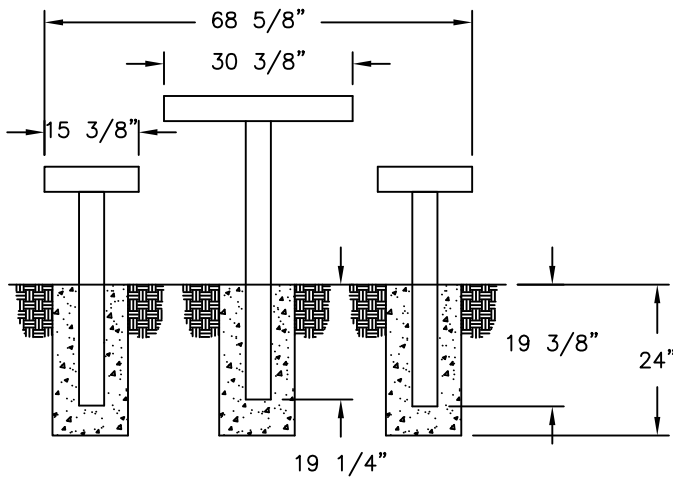

CENTER LEG USED ON 8' SS TOP

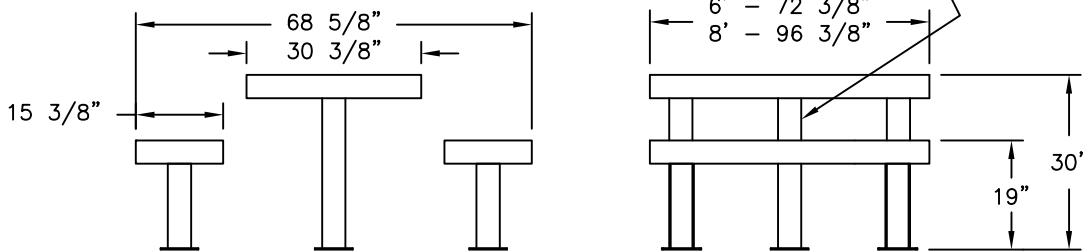

SURFACE MOUNT UNITS W/SEATS

finished assembly dimensions:

INGROUND AND SURFACE MOUNT DOUBLE SEATS

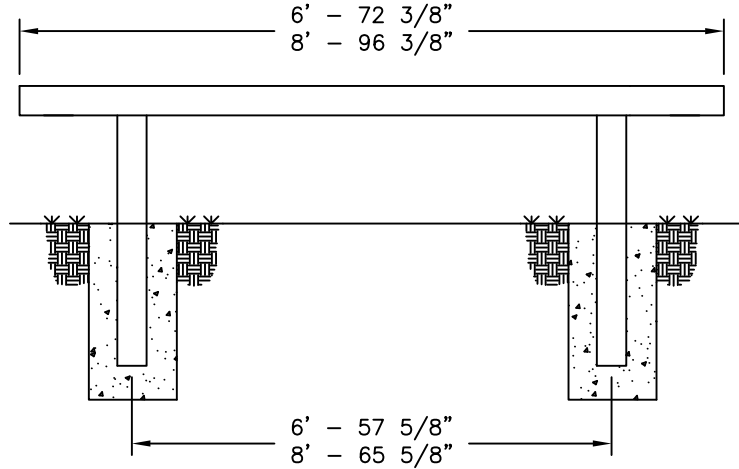
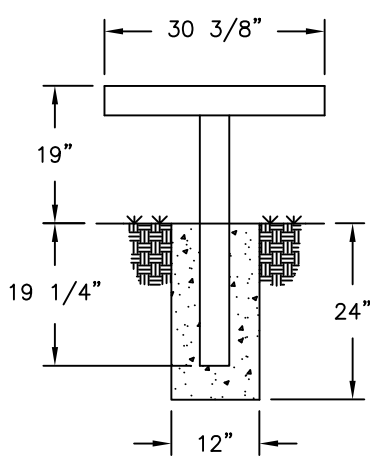

PORTABLE SEATS

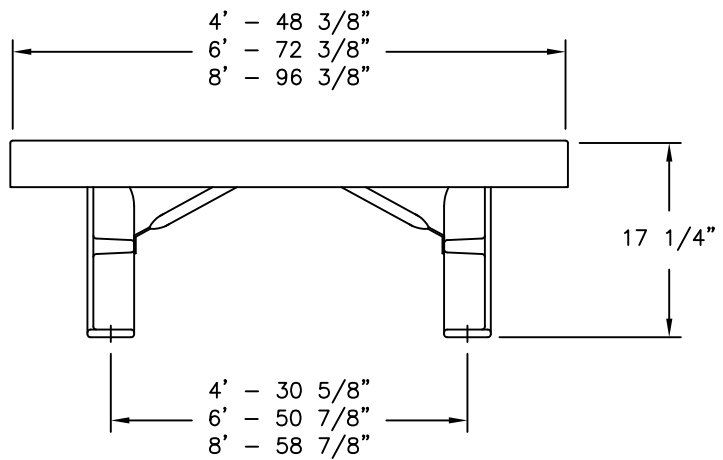
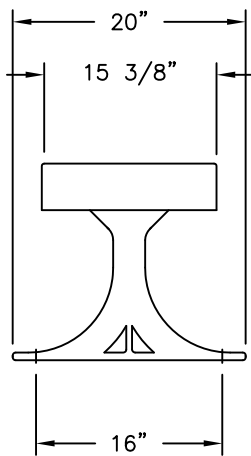

specifications cont'd:

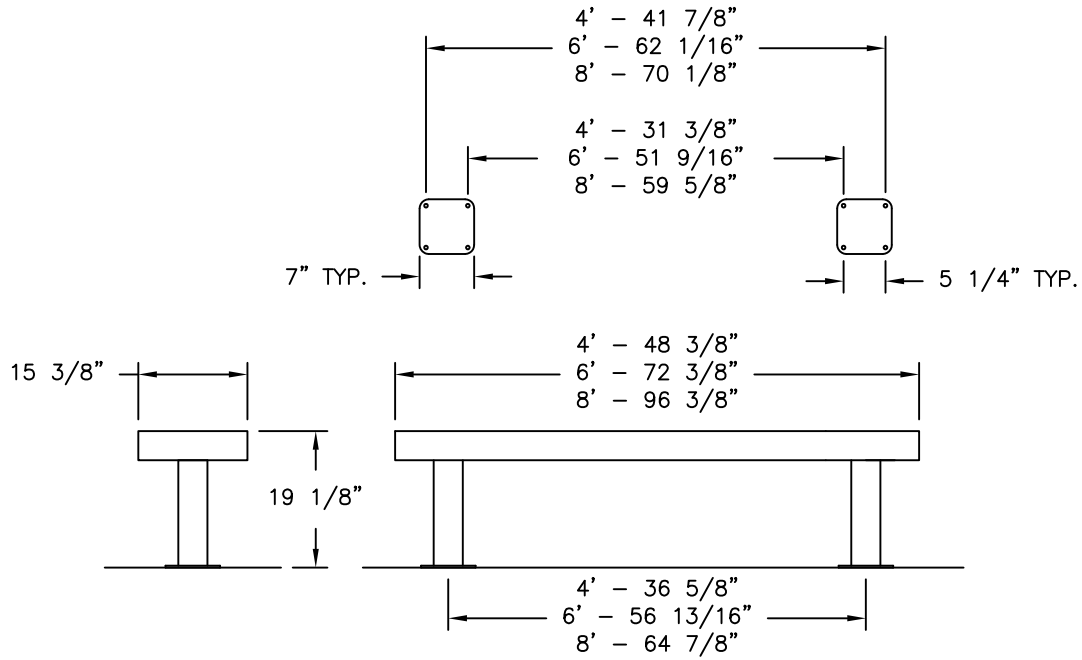

SURFACE MOUNT AND INGROUND SINGLE BENCHES

