

model no:



CN439D, CN439P, CN439R, CN439S,
CN441D, CN441P, CN441R, CN441S,

WABASH VALLEY

© Wabash Valley Manufacturing, Inc.

CONTEMPORARY SERIES

8' CONTEMPORARY BENCH & LOW PROFILE
EXPANDED METAL, PERFORATED, RIB, & SLAT
INGROUND

customer service:

ASSEMBLERS: If you find any parts missing or damaged, or if you're having difficulty assembling your furniture/equipment, call us at:
Any correspondence concerning our product should be sent directly to our **Customer Service Manager** at:

* Before calling, have your product model number available.

1-800-253-8619 (Inside U.S.A.)
260-352-2102 (Outside U.S.A.)
Monday thru Friday,
8:00 AM - 4:30 PM Eastern Time
(EXCEPT HOLIDAYS)

Wabash Valley Manufacturing, Inc.
505 E. Main Street
P.O.Box 5
Silver Lake, IN 46982 U.S.A.
FAX: 260-352-2160

maintenance:

Regular inspection and maintenance of all parts, and fasteners is necessary. Tighten all bolts and nuts. Inspect Tops, Seats, Legs, Braces and Fasteners periodically for wear or vandalism. Replace broken or worn parts immediately or take equipment out of service until repairs are made. Use genuine Wabash Valley replacement parts.

To restore plastisol coating to its luster after prolonged use, wash/rinse/dry and use Armor-All ® or similiar quality vinyl protectant.

KEEP THIS ASSEMBLY/SPECIFICATION SHEET FOR FUTURE REFERENCE.

specifications:

NOTE: We reserve the right to change specifications without notice.

Heat fused poly-vinyl coating, finished on inner-metal structure, to an approximate 3/16" thickness. Framework assemblies are finished with powder coating; electrostatically applied and oven cured according to powder manufacturer's specifications. Fasteners are stainless steel to resist corrosion.

BENCH FRAME:

Main supports are constructed of 2 7/8" od x 12 gage structural steel tubing. Attach tubes are constructed of 2 3/8" od x 12 gage and 2 7/8" od x 12 gage structural steel tubing. Mounting brackets on legs are 10 gage sheet steel and 1/4" x 1 1/2" steel flat bar. The mounting plate covers are 2 piece cast aluminum.

BENCH SEAT:

Expanded metal seat uses 3/4" #9 expanded steel. Rib pattern benches use 10 gage sheet steel. Perforated benches use 12 gage sheet steel. The slats are 3/16" x 2 1/4" flat bar. The bench's frame/mounting brackets are made from 10 gage sheet steel. Support braces, adding support to the bench's rolled-sides, are 1/4" x 1 1/4" flat bar steel.

GENERAL:

8' Contemporary bench ground space requirements are 26 3/4" x 109". The bench seat is 48 1/8" long x 26 3/4" wide and 15 3/8" to the top of the lowest part.

8' Contemporary low profile bench ground space requirements are 30 3/8" x 109". The bench seat is 72 1/8" long x 30 3/8" wide and 16 1/2" to the top of the seat.

parts identification:

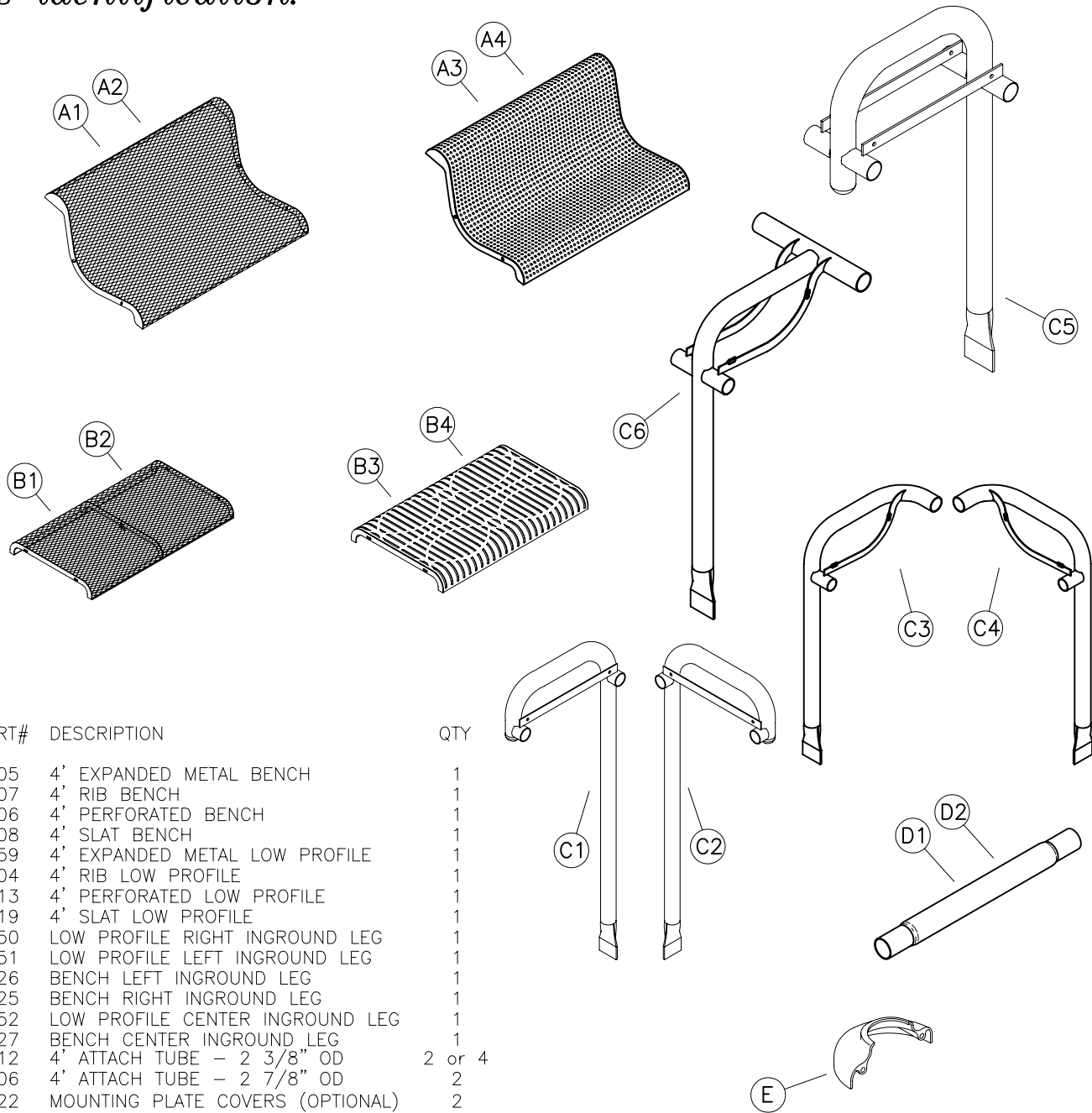

ITEM	PART#	DESCRIPTION	QTY
A1	8205	4' EXPANDED METAL BENCH	1
A2	8207	4' RIB BENCH	1
A3	8206	4' PERFORATED BENCH	1
A4	8208	4' SLAT BENCH	1
B1	7659	4' EXPANDED METAL LOW PROFILE	1
B2	7704	4' RIB LOW PROFILE	1
B3	8013	4' PERFORATED LOW PROFILE	1
B4	8119	4' SLAT LOW PROFILE	1
C1	7050	LOW PROFILE RIGHT INGROUND LEG	1
C2	7051	LOW PROFILE LEFT INGROUND LEG	1
C3	7026	BENCH LEFT INGROUND LEG	1
C4	7025	BENCH RIGHT INGROUND LEG	1
C5	7052	LOW PROFILE CENTER INGROUND LEG	1
C6	7027	BENCH CENTER INGROUND LEG	1
D1	7412	4' ATTACH TUBE - 2 3/8" OD	2 or 4
D2	7106	4' ATTACH TUBE - 2 7/8" OD	2
E	7122	MOUNTING PLATE COVERS (OPTIONAL)	2

DRAWINGS NOT TO SCALE

hardware identification:

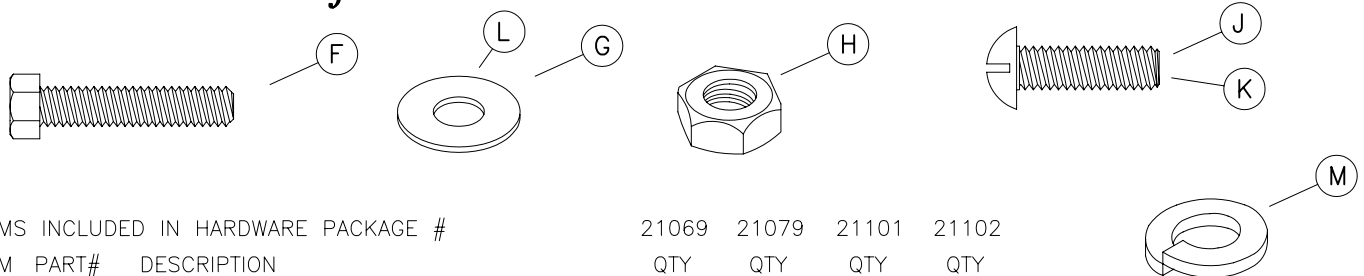

ITEMS INCLUDED IN HARDWARE PACKAGE #			21069	21079	21101	21102
ITEM	PART#	DESCRIPTION	QTY	QTY	QTY	QTY
F	17011	5/16-18 X 1 1/2" HEX HEAD BOLT - SS	4	4	0	0
G	17028	3/8" FLAT WASHER - SS	8	8	0	0
H	17032	5/16-18 HEX FINISH NUT - SS	4	4	0	0
J	17052	1/4-20 x 1" MACHINE SCREW - SS	0	0	2	0
K	17022	1/4-20 x 1/2" MACHINE SCREW - SS	0	0	0	4
L	17103	5/16" FLAT WASHER - SS	0	0	0	4
M	17050	5/16" SPLIT LOCK WASHER - SS	4	4	0	0

ASSEMBLY TOOLS REQUIRED
 1 - 1/2" WRENCHES
 1 - REGULAR TIP SCREWDRIVER
 1 - 3' OR 6' LEVEL

assembly procedures: IMPORTANT: Assemblers should be reasonably skilled in the assembly of commercial grade/heavy duty fabricated steel equipment.

To ensure proper assembly, it is suggested that you take adequate time to locate and identify each part. To prevent scratching of the finished pieces, we recommend this unit to be assembled on a clean, flat, solid, surface with a drop cloth, allowing plenty of working room. Also please read the instructions and study the sketches very carefully. A little extra time spent before assembly will be well worth it in performing a complete, proper assembly. Please note that all parts have been pre-cut and pre-drilled.

During the assembly process leave all bolts and nuts "finger tight", until the entire unit is completely assembled. This allows room for movement to level or adjust all seats, tops, benches, framework and braces if necessary. **After final adjustment and leveling, permanently tighten all nuts, bolts and fasteners.**

7L

STEP 1

Lay both (C-) right and left legs and center leg, approximately the distance of the attached tubes apart, so that the outside inground legs are on the floor with the round sleeves on each leg facing inwards, see FIG. 1. Take the ends of each attach tube and insert into the round sleeves to the front and back of each leg. Take two (D1) and (D2) attach tubes for the w/back legs or four (D1) attach tubes for the w/o back leg and insert into the round sleeves to all legs, corresponding according to each size. Be sure center leg is aligned as well.

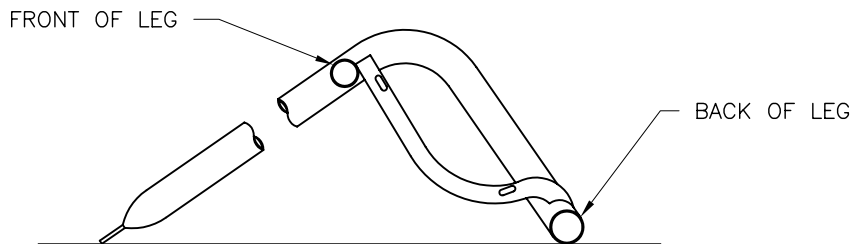

FIG. 1

STEP 2

Take the (A-) or (B-) bench seat and raise it above the bench's frame. Bring the bench seat down, aligning the mounting bracket, on each leg, to the inside of the bench seat on each end, see FIG 2 and 3.

NOTE: It may be necessary to push each leg inward to bring mounting bracket, on each leg, as close as possible to the inside of the bench seat on each end.

STEP 3

Align the holes on the ends of the bench seat, with the holes on the mounting bracket of each leg. Insert a (F) bolt and (H) nut, with two (G) and one (M) for each bolt, into all holes.

FIG. 2

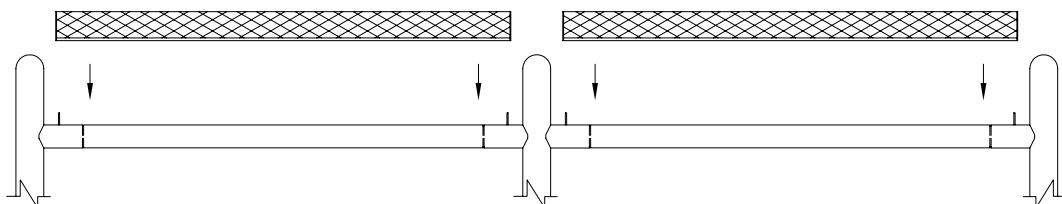

installation: WARNING: The proper installation for Wabash Valley products may depend upon many factors unique to the site, location, or use of a particular product. Consult with your contractor or other professional to determine your specific installation requirements.

assembly procedures, cont'd:

STEP 4

Adjust the bench seats by pushing the top of the bench downward in a rocking motion, while raising the front of the benches upward, to its most forward position. Draw the fasteners to a snug fit with wrenches.

NOTE: THESE INSTRUCTIONS ARE FOR BOTH THE LOW PROFILE AND CONTEMPORARY BENCHES.

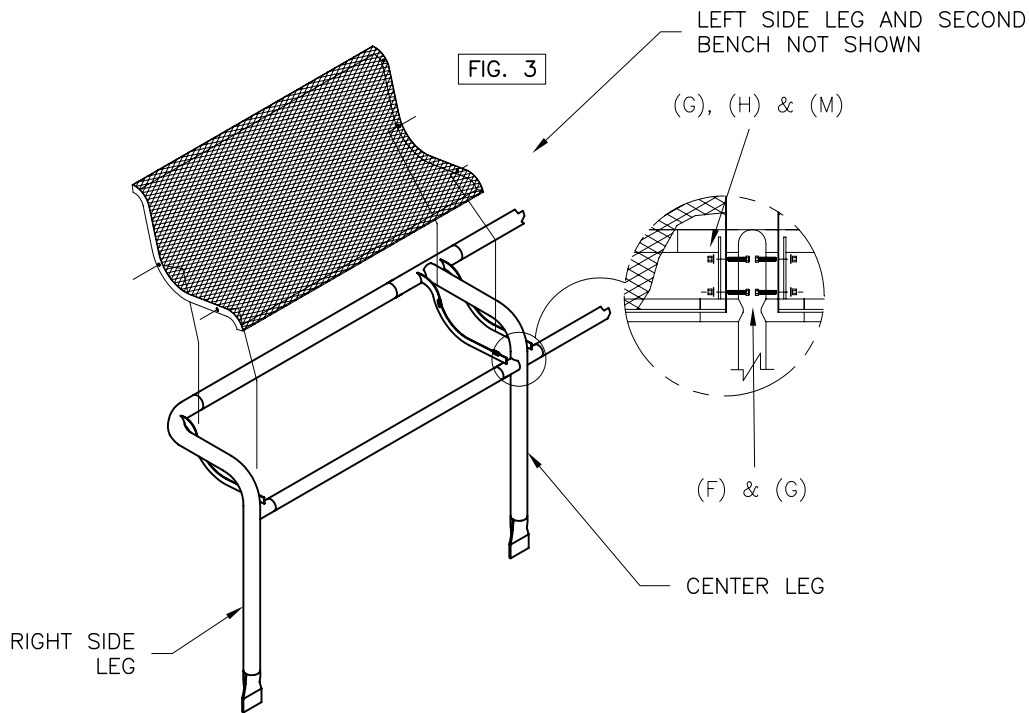

product dimensions:

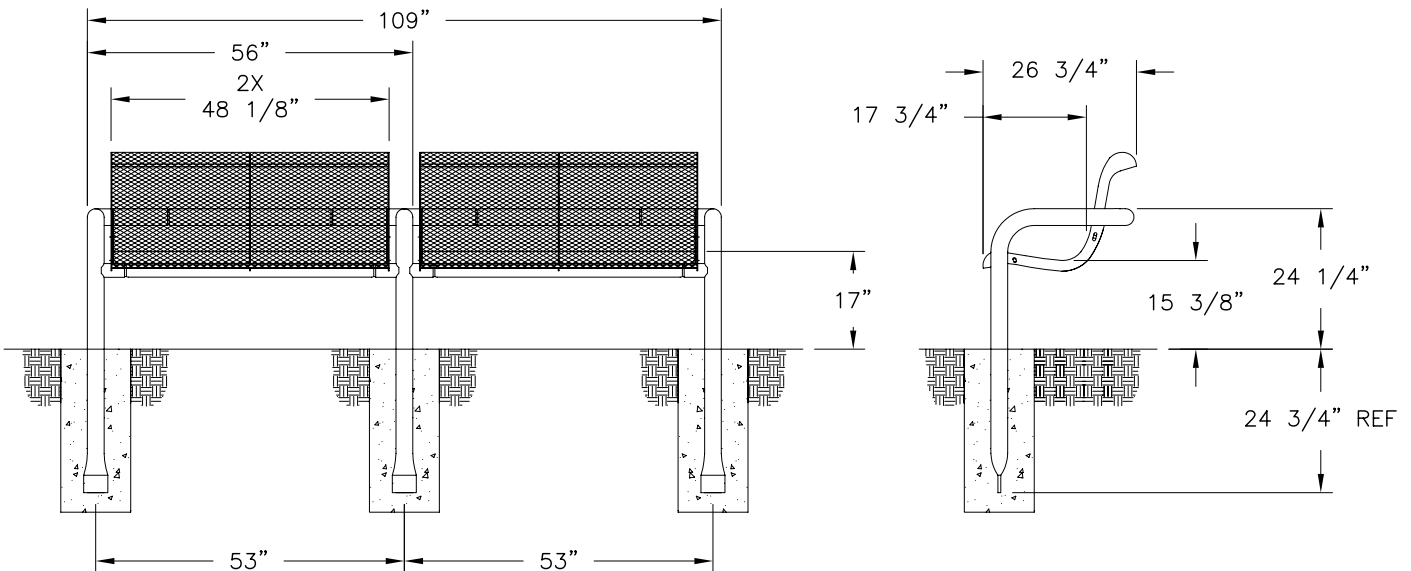

assembly procedures, cont'd:

STEP 5
Prepare the foundation holes as shown in the dimensions portion of this assembly instruction sheet. The distance of holes, center to center, is shown at the bottom of this page. Place the bench in the footing holes and block bench as shown in FIG.4. Before pouring concrete, make sure the bench is level horizontally as well as vertically and hold 16" to the top of the bench seat.

Pour concrete to form the footings and let cure for 48 hours.

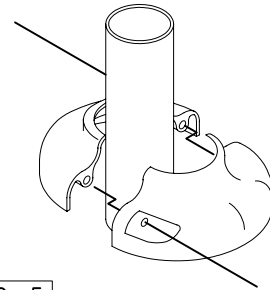
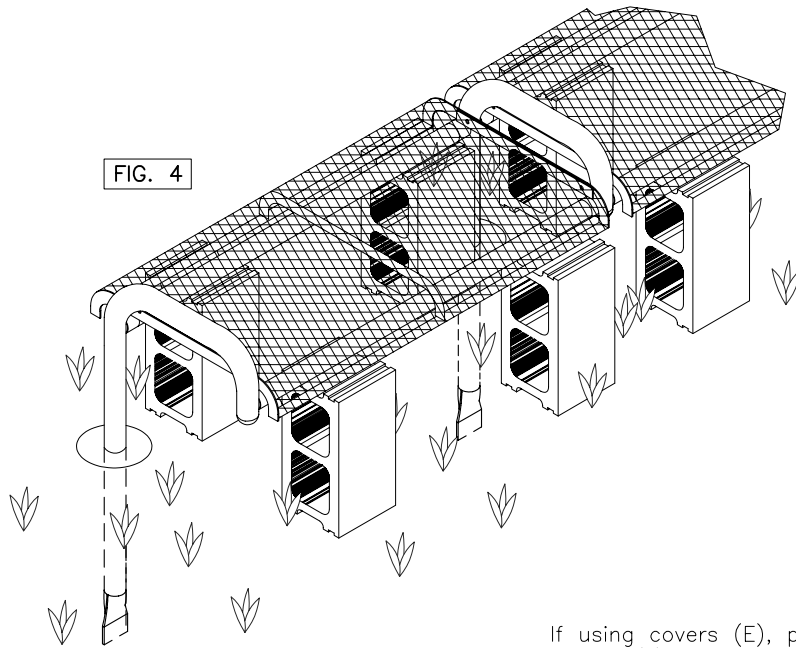

If using covers (E), place halves around leg and secure together with 2 (J) screws, see FIG. 5. Draw screws to a snug fit taking care not to over tighten.

product dimensions:

