

model no:

CM231L, CM231Q,
CM232Q, CM232L



WABASH VALLEY

CAMINO SERIES

42" ROUND TABLES W/ 4 & 5 ATTACHED CHAIRS
SOLID & SQUARE PERFORATED TOPS & PERFORATED CHAIRS

© Wabash Valley Manufacturing, Inc.

customer service:

ASSEMBLERS: If you find any parts missing or damaged, or if you're having difficulty assembling your furniture/equipment, call us at:

* Before calling, have your product model number available.

1-800-253-8619 (Inside U.S.A.)
260-352-2102 (Outside U.S.A.)
Monday thru Friday,
8:00 AM - 4:30 PM Eastern Time
(EXCEPT HOLIDAYS)

Any correspondence concerning our product should be sent directly to our Customer Service Manager at:

Wabash Valley Manufacturing, Inc.
505 E. Main Street
P.O.Box 5
Silver Lake, IN 46982 U.S.A.
FAX: 260-352-2160

maintenance:

Regular inspection and maintenance of all parts, and fasteners is necessary. Tighten all bolts and nuts. Inspect Tops, Seats, Legs, Braces and Fasteners periodically for wear or vandalism. Replace broken or worn parts immediately or take equipment out of service until repairs are made. Use genuine Wabash Valley replacement parts.

To restore plastisol coating to its luster after prolonged use, wash/rinse/dry and use Armor-All ® or similar quality vinyl protectant.

KEEP THIS ASSEMBLY/SPECIFICATION SHEET FOR FUTURE REFERENCE.

specifications:

NOTE: We reserve the right to change specifications without notice.

Heat fused poly-vinyl coating, finished on inner-metal structure, to an approximate 3/16" thickness. Framework assemblies are finished with powder coating; electrostatically applied and oven cured according to powder manufacturer's specifications. Fasteners are stainless steel to resist corrosion.

TABLE FRAME:

Main supports are constructed of 2 3/8" od x 12 gage structural steel tubing. The mounting brackets on legs are 10 gage sheet steel. The 5 Leg Center Brace is cast aluminum.

TOP & SEAT:

The square perforated top and seats are made from 12 gage sheet steel and the umbrella tube on perforated top is 14 gage x 2" steel tubing. The solid top is .190 spun aluminum sheet and the umbrella tube is 1/8" x 2" aluminum tubing. The perforated top's and seat's mounting brackets are 1/4" plate steel. The seat's framing uses 10 gage sheet steel. The solid top mounting brackets are 3/8" aluminum sheet.

SURFACE MOUNT BRACKETS:

The surface mount brackets are made from 7 gage steel plate. (For ADA only)

GENERAL:

CM232L and CM232Q ground space requirements are 91 1/8" x 96". The table top is a 41 5/8" diameter and 30 1/8" to the top of the table. Seats are 18" wide x 26 3/4" long and 19 3/8" to the top of the seat.

CM231L and CM231Q ground space requirements are 66 7/8" x 96". The table top is a 41 5/8" diameter and 30 1/8" to the top of the table. Seats are 18" wide x 26 3/4" long and 19 3/8" to the top of the seat.

NOTE: When Umbrellas are used on Tables, the Umbrellas must be secured.
Wabash Valley Umbrellas include an Umbrella Collar for securing.

parts identification:

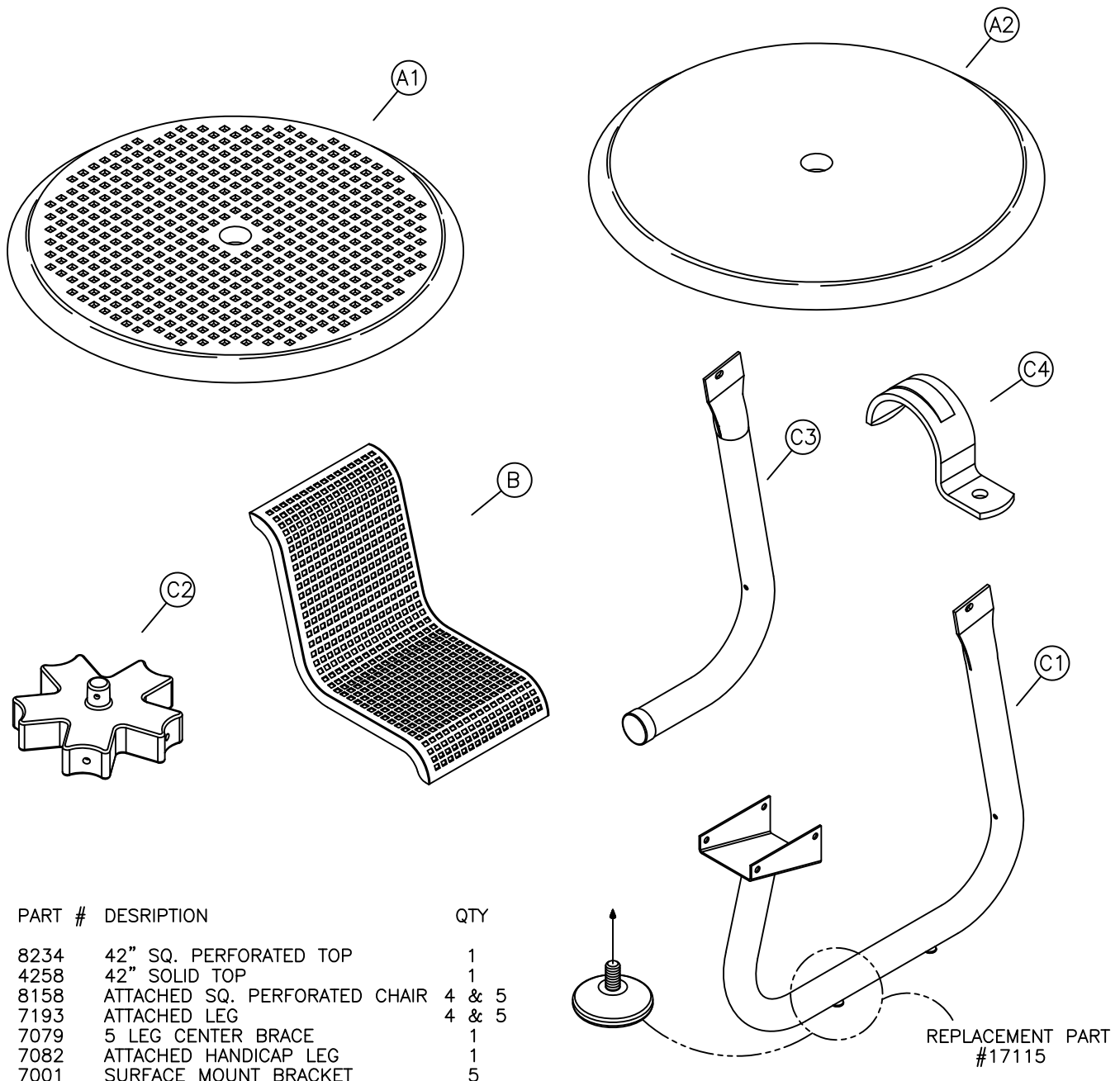

ITEM	PART #	DESCRIPTION	QTY
A1	8234	42" SQ. PERFORATED TOP	1
A2	4258	42" SOLID TOP	1
B	8158	ATTACHED SQ. PERFORATED CHAIR	4 & 5
C1	7193	ATTACHED LEG	4 & 5
C2	7079	5 LEG CENTER BRACE	1
C3	7082	ATTACHED HANDICAP LEG	1
C4	7001	SURFACE MOUNT BRACKET	5

REPLACEMENT PART #17115

hardware identification:

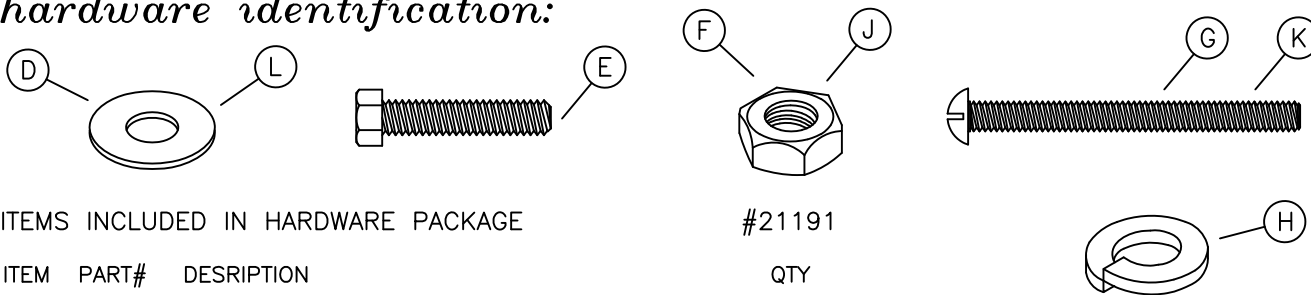

ITEMS INCLUDED IN HARDWARE PACKAGE

#21191

ITEM	PART#	DESCRIPTION	QTY
D	17028	3/8" FLAT WASHER - SS	72
E	17011	5/16-18 x 1 1/2" HEX HEAD BOLT - SS	30
F	17032	5/16-18 HEX FINISH NUT - SS	36
G	17026	5/16-18 x 3 1/2" MACHINE SCREW - SS	6
H	17050	5/16" SPLIT LOCK WASHER - SS	36
J	17017	1/4-20 FINISH NUT 18-8 - SS	1
K	17077	1/4-20 x 2" PAN HEAD MACHINE SCREW - SS	1
L	17103	5/16 FLAT WASHER - SS	2

TOOLS REQUIRED FOR ASSEMBLY

- 2 - 1/2" WRENCHES
- 1 - REGULAR TIP SCREWDRIVER
- 1 - 3' OR 6' LEVEL

assembly procedures:

IMPORTANT: Assemblers should be reasonably skilled in the assembly of commercial grade/heavy duty fabricated steel equipment.

To ensure proper assembly, it is suggested that you take adequate time to locate and identify each part. To prevent scratching of the finished pieces, we recommend this unit to be assembled on a clean, flat, solid, surface with a drop cloth, allowing plenty of working room. Also please read the instructions and study the sketches very carefully. A little extra time spent before assembly will be well worth it in performing a complete, proper assembly. Please note that all parts have been pre-cut and pre-drilled.

During the assembly process leave all bolts and nuts "finger tight", until the entire unit is completely assembled. This allows room for movement to level or adjust all seats, tops, benches, framework and braces if necessary. After final adjustment and leveling, permanently tighten all nuts, bolts and fasteners.

7L

STEP 1

Attach two opposing ends of the (C2) 5 Leg Center Brace to two (C1) legs as shown in FIG. 1. Use one, per each leg, (G), (F), (H) using two (D) per each (G). Attach the remaining three (C1) legs to the attached cross as per previous step. Tighten the fasteners with a regular tip screwdriver. **NOTE:** On four seat unit, use one (C3) leg in place of a (C1) leg.

STEP 2

Lift the (A-) top over the top end of the legs. Bring it down, aligning the top's mounting brackets off-set side to each leg see FIG. 2. Rotate and attach the top to the legs using the third mounting hole location from center of the table, see FIG. 2a. Use one per each leg, (E), (F), (H). Use two (D) per each (E).

STEP 3

Attach one (B) attached chair to the seat end of one leg. Align the leg's mounting plate to the inside of the chair's mounting brackets, see FIG. 3. Use four, per each chair, (E), (F), (H) using two (D) per (E).

NOTE: Fig. 4 shows the maximum and minimum seat positions for the two table sizes. Your personal preference will determine the seat position. Fig. 4a is the minimum for the 42" table and Fig. 4b is the maximum for the 42". Fig. 4b is also the minimum for the 36" table.

Repeat the previous step to attach the remaining three or four (B) chairs.

STEP 4

Level the top and seats if necessary and tighten fasteners with proper tools.

NOTE: ADA MODELS MUST BE ANCHORED WITH SURFACE MOUNT BRACKETS.

When using the surface mount brackets, on ADA models only, the 17115 glides are not used. Also, the surface mount bracket anchor bolts are NOT included. See Fig. 1.

FIG. 1

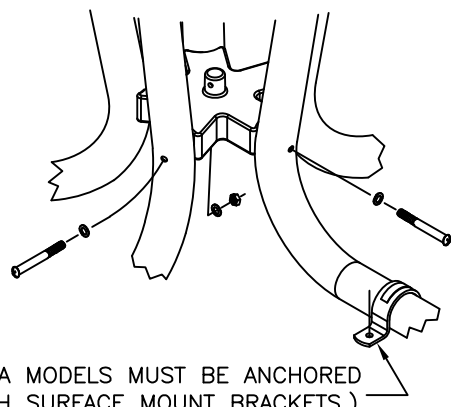

FIG. 2

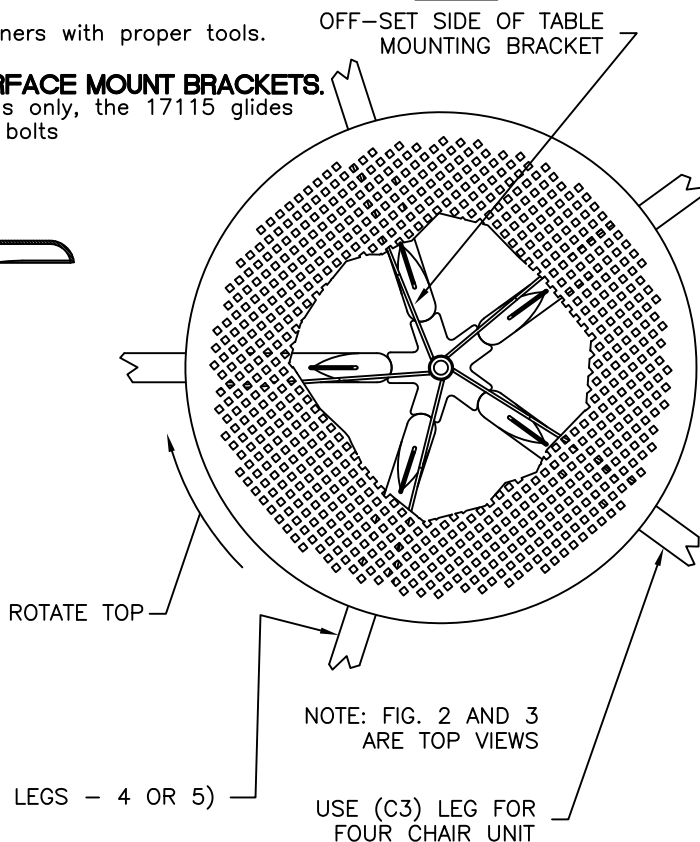

FIG. 3

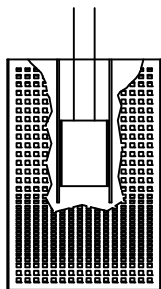

FIG. 2a

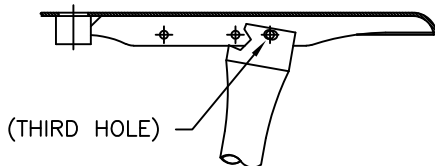
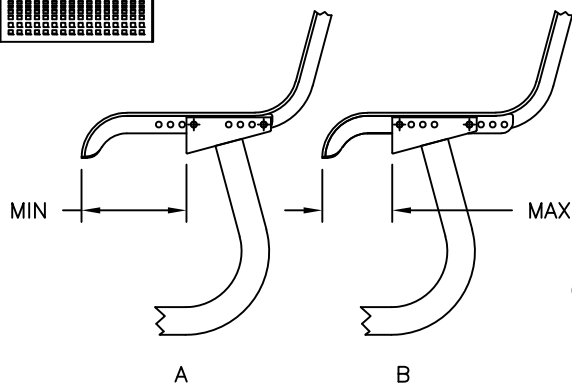

FIG. 4



installation:

WARNING: The proper installation for Wabash Valley products may depend upon many factors unique to the site, location, or use of a particular product. Consult with your contractor or other professional to determine your specific installation requirements.

product dimensions:

CM232L, CM232Q

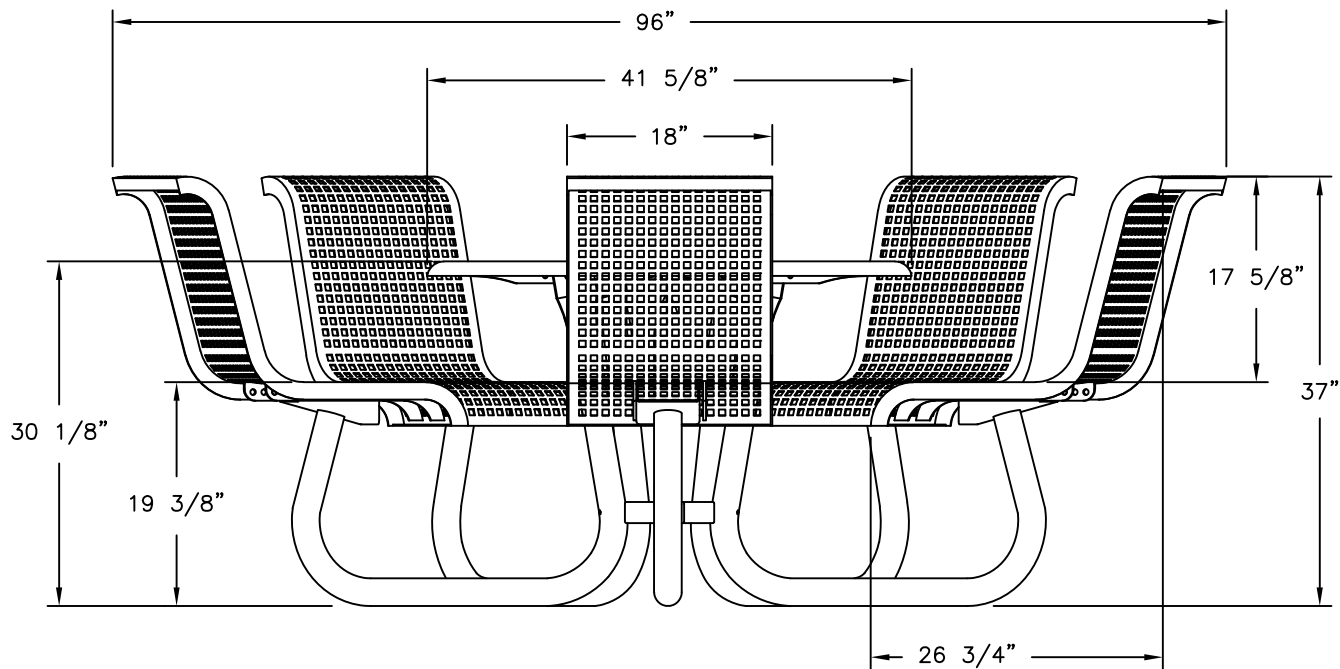

CM231L, CM231Q

(ADA MODELS MUST BE ANCHORED WITH SURFACE MOUNT BRACKETS.)

